



minipack® - torre

UNEXPECTED IDEAS

Minipack-Torre S.p.A.

Via Provinciale, 54 - 24044 Dalmine (BG) - Italy
Tel.: +39.035563525 - Fax +39.035564945
www.minipack-torre.it - info@minipack-torre.it

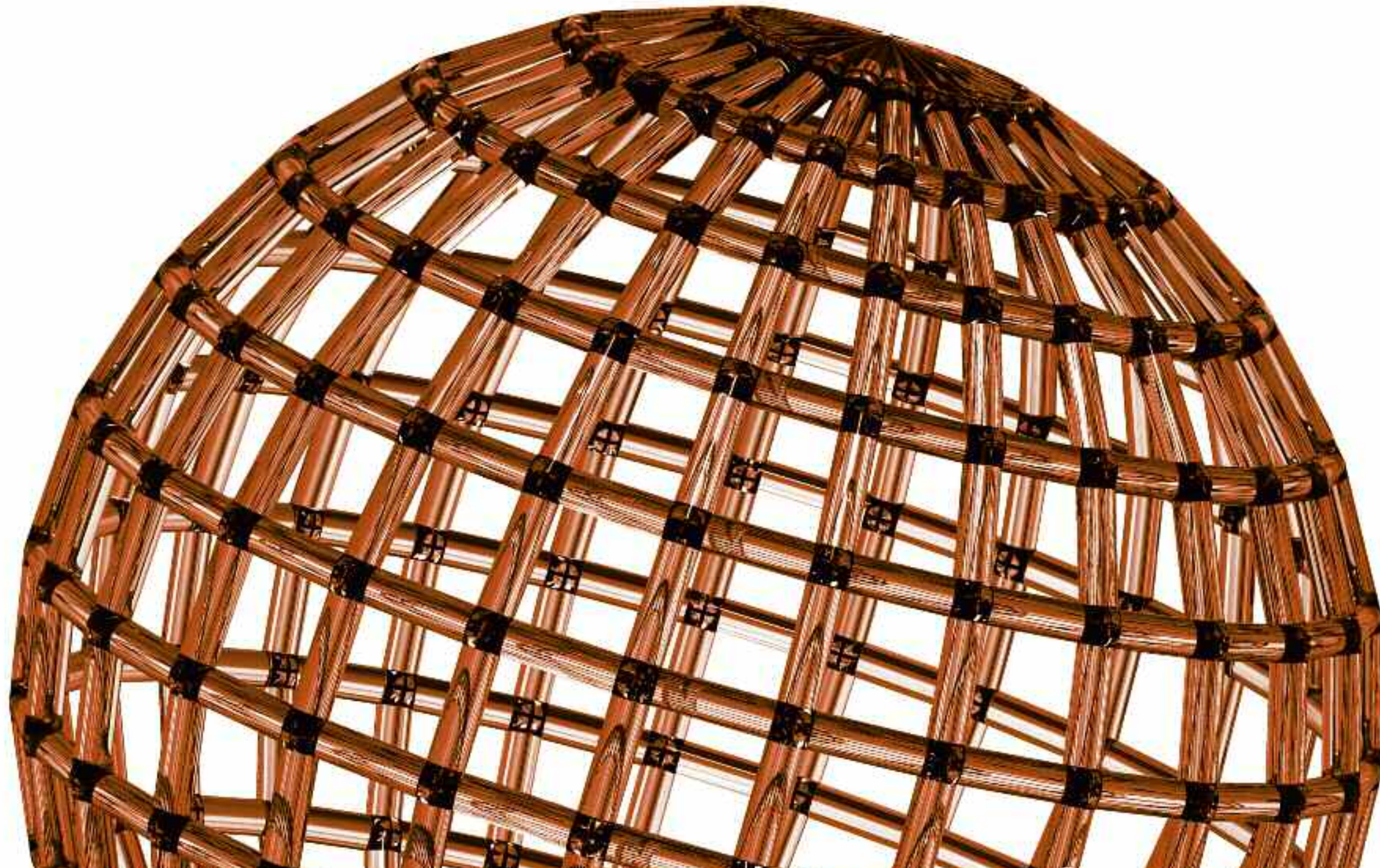

MINIPACK-TORRE



L-SEALER MACHINES

MINIPACK-TORRE. UNEXPECTED IDEAS

FACILITIES

HEADQUARTERS

MINIPACK-TORRE is located in Dalmine, a few kilometres far from Bergamo. Here there are the Finance & Control and the R&D department, as well as the shrinking and vacuum manufacturing facilities. At present time the manufacturing plant is the core of the company. This is equipped with advanced and flexible tools and CNC machines for the production of all the mechanical components.

SALES DEPARTMENT

According to the policy of the company to expand and consolidate itself on the market, since some years a new building has been realised near the Headquarters. Inside there is: the sales department, the warehouse and logistic department, a 100 seat theatre for sales meeting and technical training and, last but not least, a wide show room where the whole range of machines is displayed. These are always at distributors and customers disposal for all the kind of tests to be made.

STEELWORKS

Situated in the manufacturing plant in Osio Sotto (Bg), close to the Headquarters, there is the completely automated steelworks, with Hi-Tech equipment for the production of all the chassis.

Ten world-wide patented models, four technological advanced production facilities (one completely automated), a world-wide distribution network, a widespread technical assistance, the Certificate of Quality UNI EN ISO 9001:2000: this is what today MINIPACK-TORRE is.

In more than 30 years the company has gained a world-wide leader position in the packaging machines field. Any equipment provided is reliable, ensures a good productivity and always impresses for the great ideas which has.

R&D.

Every year 5% of the general turnover is invested in R&D. This continuous research allows MINIPACK-TORRE to always be on the top level of a market which is constantly in evolution. Thanks to the R&D department the company is always able to offer new advanced and reliable packaging systems.

SAFETY: TOP PRIORITY.

More than others, MINIPACK-TORRE has taken into great consideration the safety of the operators of their machines. That is why they deeply and continuously studied and developed new safety systems.

Hi-TECH MANUFACTURING PLANTS.

The manufacturing plants are completely automatised. The staff is continuously working in order to fulfil any specific and customised requirements from all the customers.

GOING-OVER CONTROLS.

All the materials and components are of first quality. Moreover each production step is supervised by technical skilled employees, each machine is submitted to strict tests and to a long final inspection before being delivered.

QUALITY POLICY.

The two Certificates of Quality UNI EN ISO 9001 - VISION 2000 obtained in the year 2001 represent an important goal and a never-ended engagement to satisfy the customers thanks to a strict quality control procedure in production, commercial services and after sales assistance.

DESIGN AND PRODUCTION.

We believe that in order to achieve goods results, every single project has to be personally followed from the beginning to the end. At MINIPACK-TORRE all the steps of a project are entirely developed inside the company. That is why a steelworks has been created inside the company to build all the chassis and the whole components of the machines. This gives a great flexibility to the whole structure.

WIDESPREAD COMMERCIAL NETWORK AND AFTER SALES ASSISTANCE

Thanks to 2 sister companies in France and in the United States along with more than 110 sales distributors all over the world (25 of which just in Italy) MINIPACK-TORRE is able to provide a widespread and efficient sales network. Moreover the after sales department along with the commercial staff of MINIPACK-TORRE regularly organises sales and technical meetings to train the wide number of distributors and reps. An adequate technical knowledge is compulsory to give the best possible service to the thousands end uses of MINIPACK-TORRE machines.



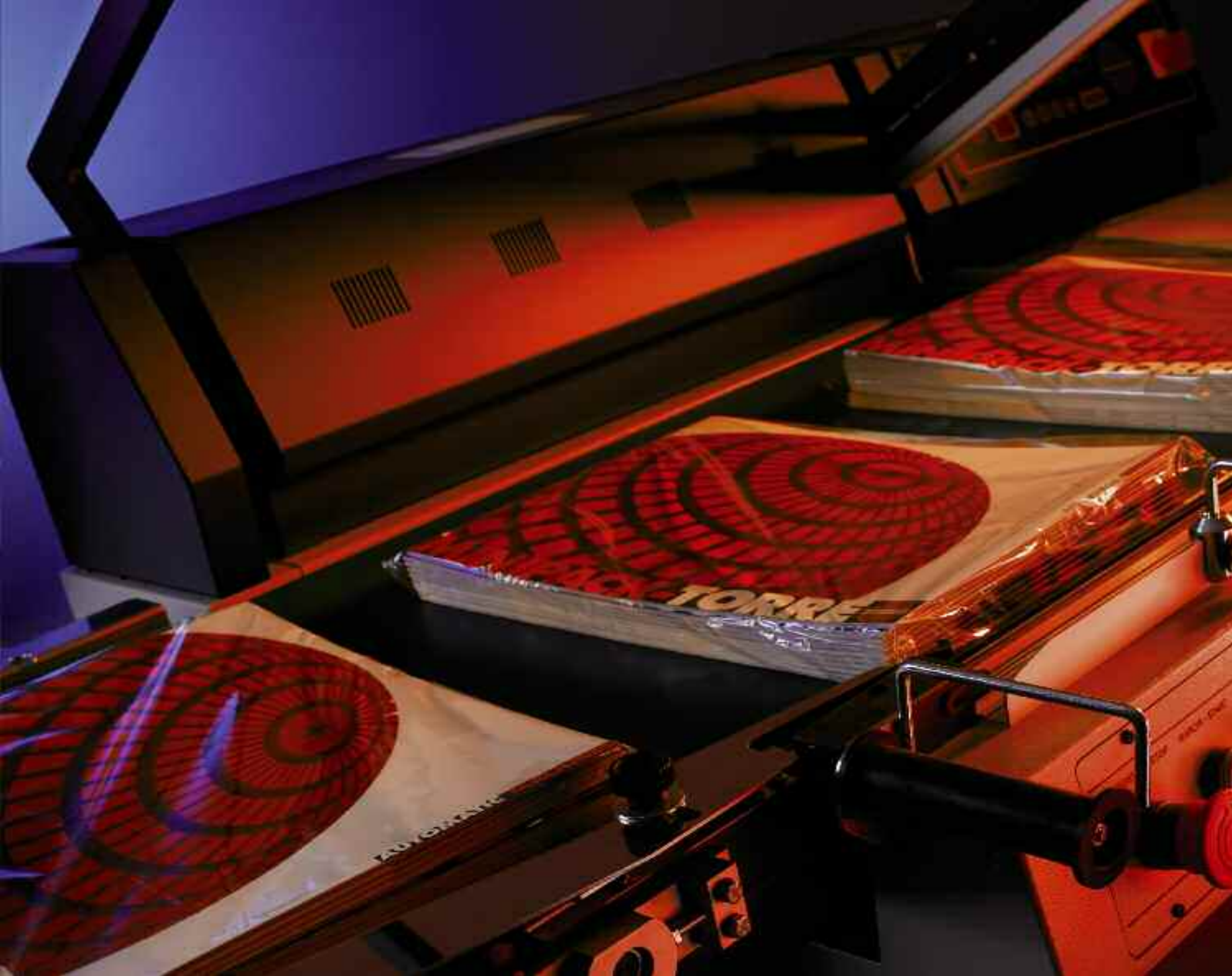

MODULAR LINE

MAXIMUM FLEXIBILITY, MINIMUM EFFORT.

The MODULAR LINE semi-automatic, angular machines offer maximum packaging flexibility, and a quality product at a competitive price.

MODULAR 50s and MODULAR 70, which have recently been updated and revised, can be used to package products using any material, producing highly attractive results.

MODULAR LINE uses an electronically

controlled sealing system and the very latest safety devices.

The lines can be used in automatic or semi-automatic mode, and the operating programs can be customised in order to simplify the packaging process and maximise productivity.

MODULAR 50s and MODULAR 70 can also be used with the MINIPACK-TORRE TUNNEL LINE.



MODULAR 50S MODULAR 70

FEATURES

- Teflon coated sealing blade
- Double sealing bar with shock absorber
- Continuous cycle cooling system
- Manual or automatic mode
- Adjustable working plate
- Motor driven conveyor belt with adjustable speed
- Oversized waste film winder
- Integrated roll support
- Digital panel with 6 programs
- Product counter
- Lockable packaging plate
- Bar opening delay allows sealer to cool down
- Machine on wheels
- Emergency off switch

TECHNICAL DATA

		MODULAR 50s	MODULAR 70
Electrical power supply	V	200/208/220/380/415	200/208/220/380/415
Maximum power	kW	2,9	2,6
Production per hour*	p/h	0-900	0-900
Effective sealing bar dimensions	mm	540 x 400	840 x 600
	in	21 x 16	33 x 24
Max. roll dimensions	mm	Ø 250 x 600	Ø 300 x 800
	in	Ø 10 x 24	12 x 31
Working plate height	mm	930	930
	in	37	37
Machine dimensions (with hood open)	mm	1590 x 750 x 1400	2070 x 960 x 1510
	in	63 x 30 x 55	81 x 38 x 59
Machine dimensions (with hood closed)	mm	1590 x 750 x 1110	2070 x 960 x 1220
	in	63 x 30 x 44	81 x 38 x 48
Packed machine dimensions	mm	1480 x 1000 x 850	2180 x 1040 x 1430
	in	58 x 39 x 33	86 x 41 x 56
Machine weight (Net/Gross)	kg	151/181	243/290
	pound	67/82	110/132

* Depends on type of product, film and operator ability.

OPTIONAL

- Stainless steel packaging plate
- Film opener bar
- Bars with ceramic sectors for use with polyethylene
- Outfeed rollers for unloading the product
- Dual roll support (50s)
- Pedal control (50s)



MODULAR 50s



MODULAR 70

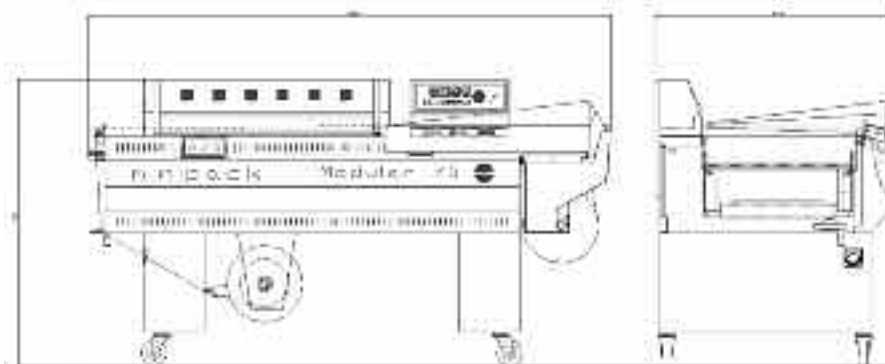
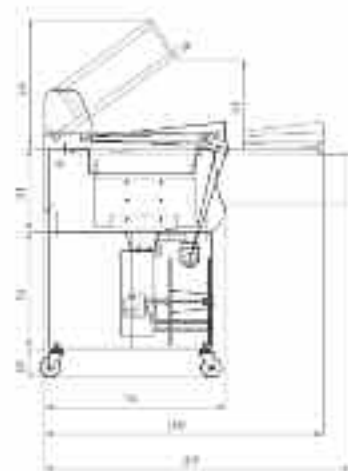
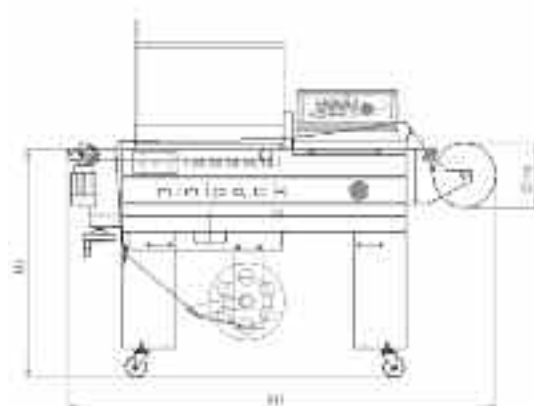



MEDIA

THE VIRTUE OF COMPACTNESS.

The MINIPACK-TORRE range of modular, semiautomatic angular machines is completed by MEDIA, with its distinctive monoblock structure. The shrinking tunnel, with adjustable temperature height and speed is incorporated with the sealing unit: this solution renders the machine more compact and versatile.

MEDIA retains all the high profile

technological features: the sealing time is electronically regulated and teflon coated blades ensure that no fumes are generated. The "on board" equipment leaves nothing to be desired either: the sealing bar and motor driven waste winder are fitted as standard.

MEDIA a packaging machine for companies that think big!



MEDIA

TECHNICAL DATA

Electrical power supply	V	200/208/220/380/415
Maximum power	kW	5.6
Production per hour*	(pph)	0-900
Effective sealing bar dimensions	mm in	540 x 400 21 x 16
Max. roll dimensions	mm in	Ø 350 x 600 Ø14 x 24
Working plate height	mm in	875 34
Machine dimensions (with hood open)	mm in	2330 x 730 x 1380 (motor) 92 x 29 x 54 (motor)
Machine dimensions (with hood closed)	mm in	2330 x 730 x 1380 (motor) 92 x 29 x 54 (motor)
Packed machine dimensions	mm in	2500 x 900 x 1510 98 x 35 x 59
Machine weight (Net/Gross)	kg pound	287/343 130/156
Tunnel infeed dimensions	mm in	440 x 240 17 x 10

* Depends on type of product, film and operator ability.

OPTIONAL

Stainless steel sealing plate
Blower
Film separator sheet
Stainless steel 0.5 mt. / 20 in Roller conveyor
1 mt. / 40 in Roller conveyor
Teflon tunnel belt
Sealing belt for foodstuffs

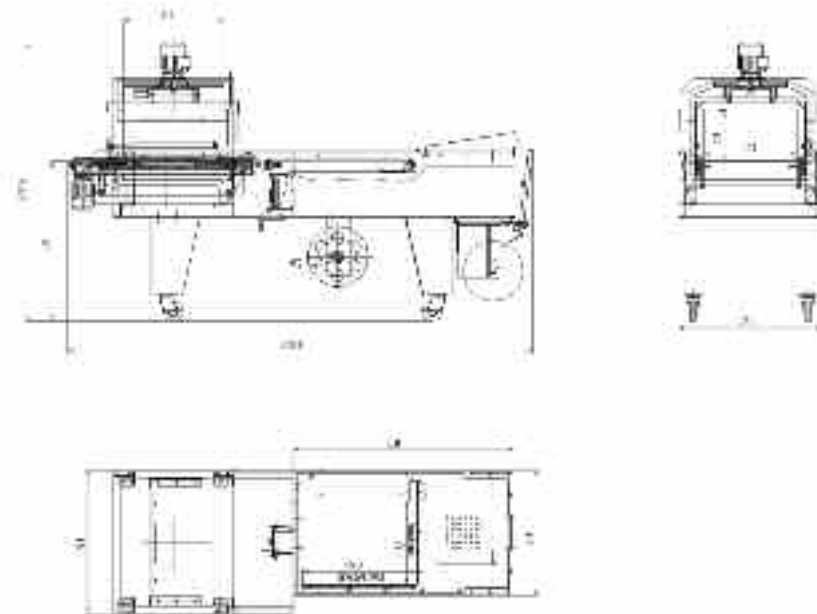

FEATURES

- Electromechanical automation
- Automatic sealing speed regulator
- Adjustable height motor driven conveyor belt
- Waste winder
- Sealing bars with closed circuit cooling system and patented safety system
- Orientable shrinking tunnel air flow
- Adjustable temperature with electronic thermo-regulator
- Thermally isolated structure

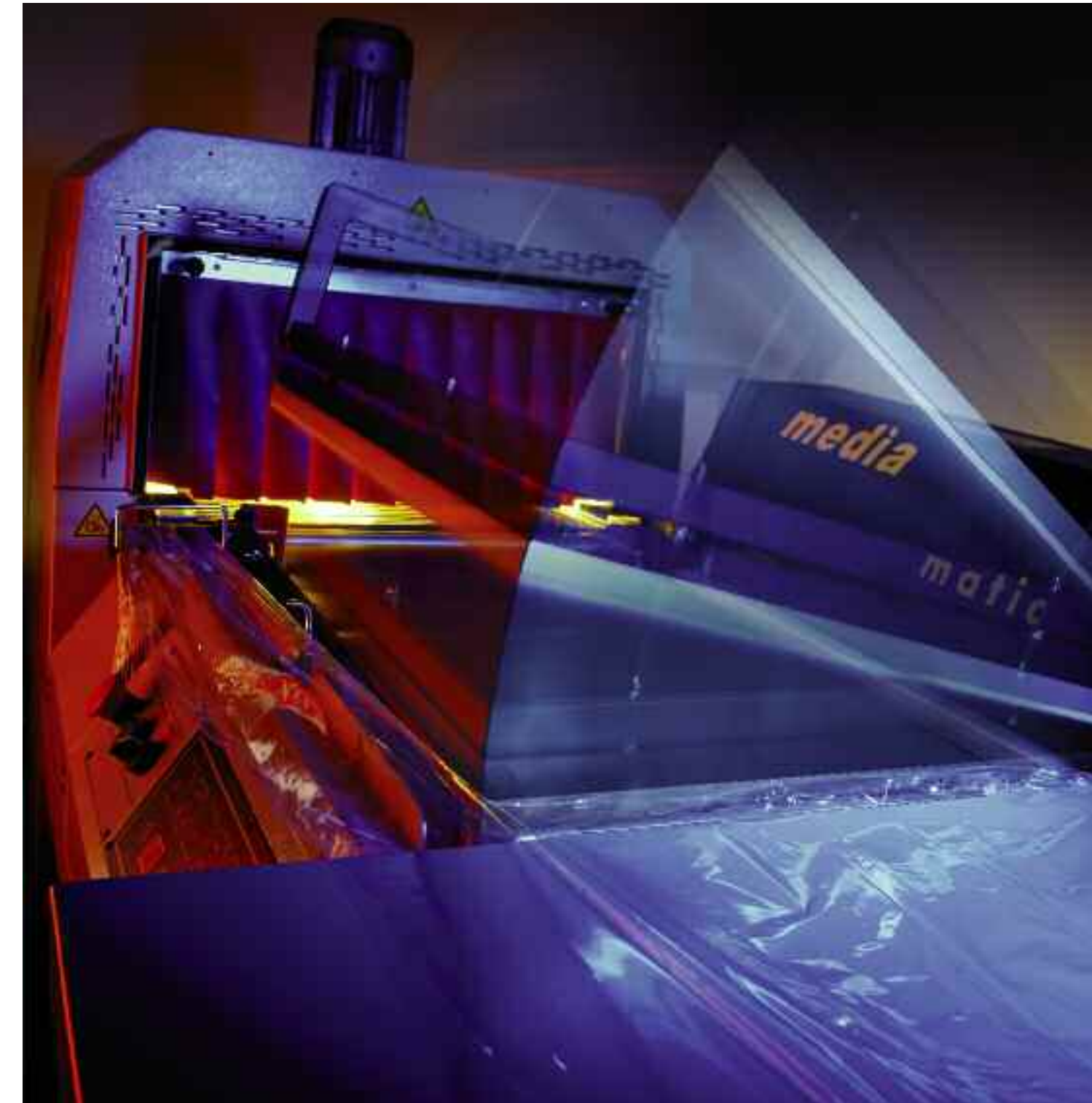

ECOMODULAR

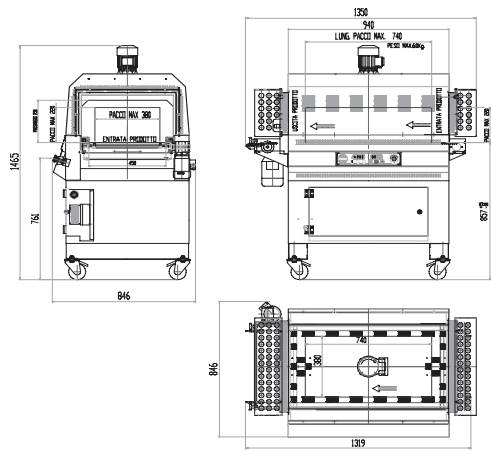

TECHNICAL DATA

Electrical power supply	V	120/208/220
Maximum power	kW	2.3
Production per hour*	(pph)	0-550
Effective sealing bar dimensions	mm in	540 x 390 21 x 15
Max. roll dimensions	mm in	Ø 250 x 600 Ø 10 x 24
Working plate height	mm in	930 37
Machine dimensions (with hood open)	mm in	1570 x 730 x 1400 62 x 29 x 55
Machine dimensions (with hood closed)	mm in	1570 x 730 x 1100 62 x 29 x 43
Packed machine dimensions	mm in	1415 x 955 x 840 56 x 38 x 33
Machine weight (Net/Gross)	kg pound	101/130 46/59

* Depends on type of product, film and operator ability.

WIDTH

ECOMODULAR, the practical and easy to use manual, angular sealing machine is notable for its large (570x420 mm) sealing surface. The sealing blade, located in the lower part of the machine, is equipped with a simple and effective temperature control system that produces optimum results with all film types. This machine, produced by MINIPACK-TORRE, is available in the basic (fixed plate) and automatic (with product ejection mat)

can be used in conjunction with TUNNEL 50. This solution guarantees perfectly heat shrunk packages capable of satisfying any packaging requirement.

OPTIONAL

Stainless steel sealing plate
Blower
Double roll support
Film separator sheet
Roller conveyor

TUNNEL LINE

**FLEXIBLE AND
UPDATED SOLUTIONS
TO GET THE BEST
PACKAGING.**

TUNNEL 50 and 70 are a master piece in MINIPACK-TORRE shrinking devices. Now on the market with up to dated solutions to pack with maximum efficacy the most different kind of shrinking film.

The stainless steel version (TUNNEL 50) is perfect for food or pharmaceutical applications.

TUNNEL 50 TWIN é has been designed to solve the needs to pack small product at high speed with great technical and esthetical results. Double heating chamber, double heating regulation, excellent thermal insulation, high speed belt and high speed shrink, great air flow control makes this machine the perfect tool to solve any kind of shrink problem with the maximum efficacy.





TUNNEL 50



TUNNEL 50 TWIN



TUNNEL 70

TUNNEL 50 TUNNEL 50 INOX TUNNEL 50 TWIN TUNNEL 70

**FLEXIBLE AND
UPDATED SOLUTIONS
TO GET THE BEST
PACKAGING.**

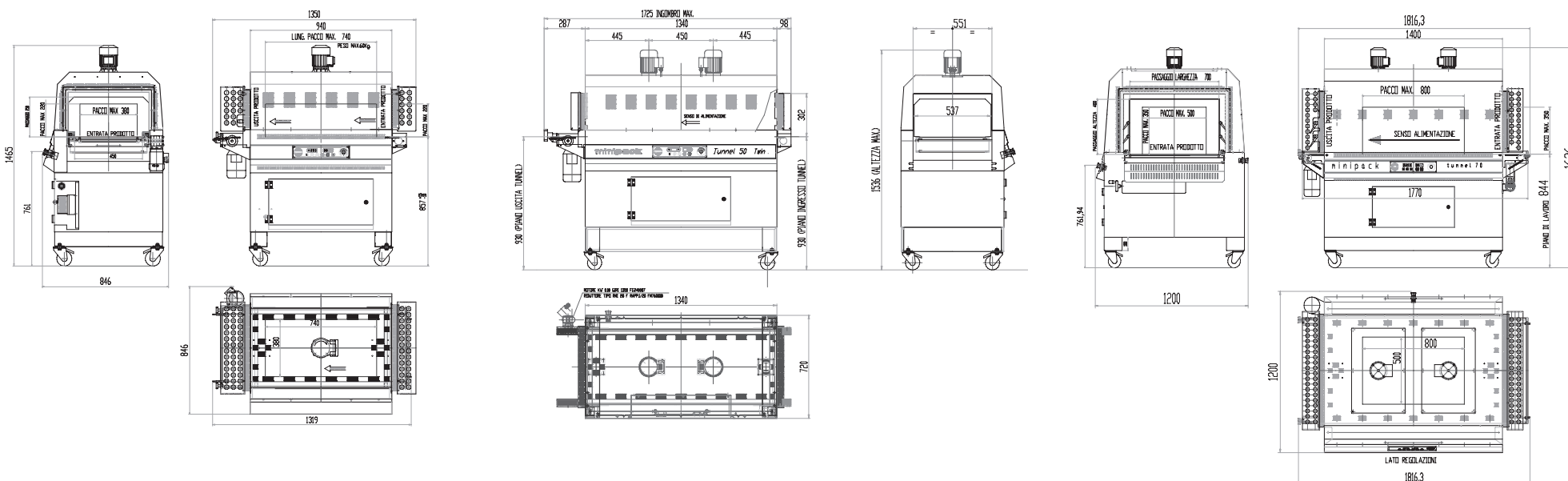

TECHNICAL DATA

		TUNNEL 50 / 50 INOX	TUNNEL 50 TWIN	TUNNEL 70
Power supply	V	200/208/220/380/415/440	200/208/220/380/415	200/208/220/380
Power max.	Kw	7	14	14
Conveyor speed	Min	m/min 1	2	1
	Medium	m/min 5	10	5
	Max	m/min 12	24	12
Max product dimensions	mm	380x220 lg.740	380x190 lg.1140	500x350 lg.1200
	in	14.96x8.66 lg. 29,13	14.96x7,47 lg.44.88	19.69x13.78 lg47.23
In-feed working belt height	mm	850/880	850/880	845/875
	in	33.45/34.63	33.45/34.63	33.27/34.45
Out-feed working belt height	mm	850	850	845
	in	33.45	33.45	33.27
Machine dimensions	mm	1770 x 840 h.1465	2130 x 800 h.1460	2770 x 1160 h.1640
	in	69,66x33.06 h.57.66	83.83x31.48 h.57.46	109,02x45.65 h.64.55
Packed machine dimensions	mm	1390 x 910 h.1640	1930 x 980 h.1745	2030 x 1230 h.1830
	in	54.71x35.81 h.64.55	75.96x38.57 h.68.68	79.90x48.41 h.72,02
Machine weight (net/gross)	Kg	188/228	260/318	415/483
	pound	414/502	572/700	913/1063
Tunnel entrance dimension	mm	450x240	450x210	690x390
	in	17.71x9.45	17.71x8,26	27.16x15.35

FEATURES

- Manual regulation of conveyor height
- Digital display with 9 storable programs
- Selection of self rotation of conveyors rolls
- Double air flap
- Auto switch-off
- Exit roll conveyor
- Two independent heating rooms

OPTIONAL

- Plexiglas thermal protections at the inlet and outlet of the tunnel
- Teflon belt
- Metal belt