

Technical Data	0059/0559	1059/1559	1053/1553	2053/2553	3053/3553	4053/4553
Loading area max., mm (W x L)	720x1.040	890x1.260	890x1.260	1.020x1.440	1.220x1.640	1.550x2.220*
Loading area max., inch (W x L)	28,35x40,94	35,04x49,61	35,04x49,61	40,16x56,69	48,03x64,57	61,02x87,40
Loading area min., mm (W x L)	100x180	100x180	100x280	100x280	100x280	100x280
Loading area min., inch (W x L)	3,94x7,09	3,94x7,09	3,94x11,02	3,94x11,02	3,94x11,02	3,94x11,02
Single material depth min., mm/inch	100/3,94	100/3,94	100/3,94	100/3,94	100/3,94	100/3,94
Ream height, mm/inch	165/6,5	165/6,5	165/6,5	165/6,5	165/6,5	195/7,68
Stack height with pallet max., mm/inch	1.015/39,96	1.015/39,96	1.650/64,96	1.650/64,96	1.650/64,96	1.650/64,96
Table bearing capacity approx., kg	200	200	200	300	300	500
Time for one work cycle approx., sec.	20-32	20-32	25-37	25-37	25-37	28-40
<b>A</b> Length, mm/inch	2.230/87,80	2.350/92,52	3.230/127,17	3.760/148,03	4.160/163,78	5.645/222,24
<b>B</b> Depth, mm/inch	1.500/59,06	1.720/67,72	1.730/68,11	2.170/85,43	2.370/93,31	2.570/101,18
<b>C</b> Height, mm/inch	1.440/56,69	1.440/56,69	2.050/80,71	2.140/84,25	2.140/84,25	2.520/99,21
<b>D</b> Table length, mm/inch	1.270/50,00	1.470/57,87	1.820/71,65	2.250/88,58	2.450/96,46	2.680/105,51
<b>E</b> Table depth, mm/inch	765/30,12	970/38,19	1.010/39,76	1.150/45,28	1.350/53,15	1.410/55,51
Work flow direction, from-to	l.-r./r.-l.	l.-r./r.-l.	l.-r./r.-l.	l.-r./r.-l.	l.-r./r.-l.	l.-r./r.-l.
Total weight, kg	1.300/2.866	1.350/2.976	1.550/3.417	3.000/6.614	3.200/7.055	3.600/7.937
Air pressure, bar / l/min.	6 / 10	6 / 10	6 / 10	6 / 10	6 / 10	6 / 10
Power required, kW	2,5	2,5	4,5	4,5	4,5	4,5

Subject to technical modifications. Errors excepted.

### Dimensions

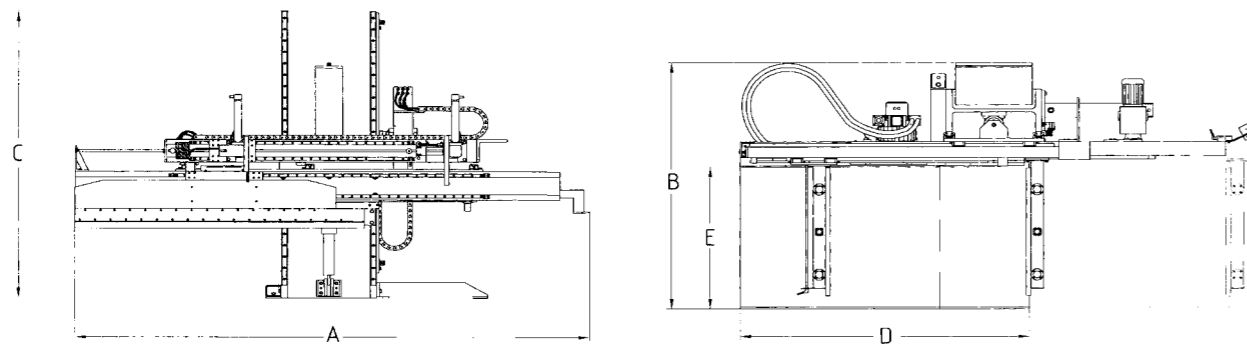

**SCHNEIDER  
SENATOR**

dealer  
stamp

Printed in Germany 02.2010

## A restack above the rest.

**PROFI**-line Restacker



# A better grip on things.

**PROFI**-line



Compact and reasonably priced: Restacker xx59

## Performance: Perfect.

The processed material is pushed onto the table, positioned at loading height. The material is lined up against the back stop and the lowered lateral edge. The opposite positioning ruler is lowered and holds the material against the lateral alignment stop. Next the table and the stops with the material travel into the proper stacking position across the pallet. The material is now positioned directly above the pallet. The material is placed in precise alignment onto the stack by removing the table from beneath and returning it automatically to its original position. Simultaneous stacking of variable sizes of material is carried out with precise alignment and minimal abrasion. There is negligible height difference to overcome. The material is permanently clamped during the entire process.

## Safety: First.

The electronic program controls are equipped with a feedback system. Light beams and contact strips restrict the operation range of the transport table and prevent damage or jamming of the stack. The operator side of the unit is also protected against unauthorized entry.

## Installation: Simple.

The solid foundation of the tower is anchored to the floor with four steel bolts. After the horizontal and vertical alignment of the machine is completed, the electric and pneumatic lines are connected. Your restacker is ready to work!

## Design: Uncompromising.

The stationary, hydraulic drive system is housed in a stable tower unit with a projecting suspension platform. The air blown steel table with stainless steel surface (V2A) is moved on linear ball bearings along hardened precision guides. The stacking unit is equipped with an electronic computerized control system for automatic operation.

## Advantages: Persuasive.

- Fully automatic operation for mark-free, completely aligned stacking
- Optimized material flow, one man operation, no physical strain
- Direct processing or dispatch without production transfer
- Ultimate precision - time after time - even with small-size loads
- Materials are clamped from two sides, making movements impossible
- Large, robust tower construction for reliable, continuous output
- Vibration-free
- High-quality, air-blown, extremely flat stainless steel table
- Wear-resistant hydraulic/pneumatic drive unit
- Siemens SP control system - low maintenance and service-friendly
- Precision linear guides for friction free, high tolerance operation even under heavy load conditions
- Adjustable table height
- Ergonomically designed operator panel
- Additional batch for perfect aligning

## Options: The Extras.

- Staggered restacking
- Intermediate layer (available from type 3x53)
- Restacking on up to 4 different pallets
- Special colour according to RAL scale

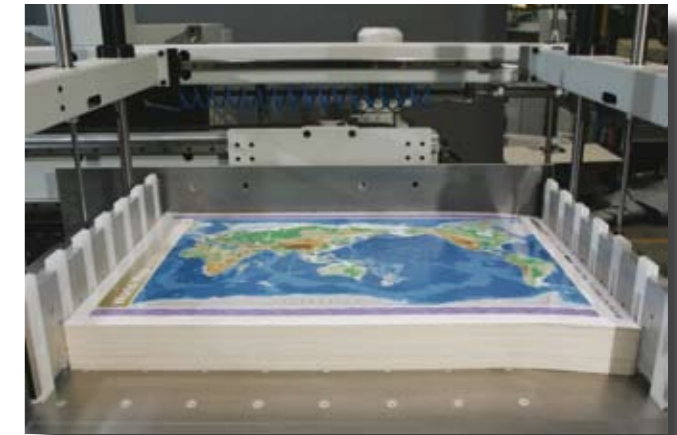

Precise clamping of the tiers



Cutting system with a restacker



Restacker in operation

RESTACKER